

Sanicubic 1 GR HP

Grey water, black water

The Sanicubic 1 GR HP high-performance lifting station is designed for pumping black waste water from individual houses, flats, pool houses or small businesses. The automatic control is pneumatic through an internal immersion pipe. A wired control unit and an alarm system are included.

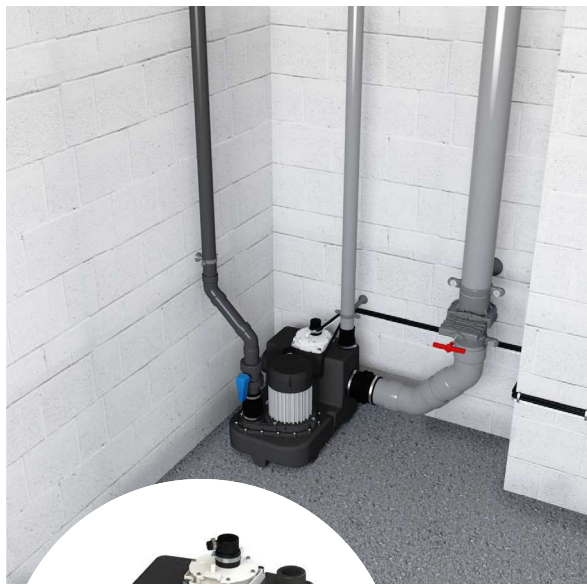

PERFORMANCE

- Max. head : 18 m
- Max. flow rate : 17 m³/h

PRODUCT BENEFITS

- Floor standing for easy installation
- Easy access to the pressure switch and motor for maintenance
- Pro XK2 stainless steel grinder technology
- Can handle water temperatures up to 90°C (max 5 mins)
- 2 side inlets DN 100 mm
- Non-return valve included
- Control box and alarm included



See page 10



DELIVERED AS STANDARD



Remote wired audible and visual alarm unit (5m)



Classic control box

OPTIONAL EXTRAS



Sanicubic carbon filter
Product code: 1108
Barcode: 3308815077529

DIMENSIONS

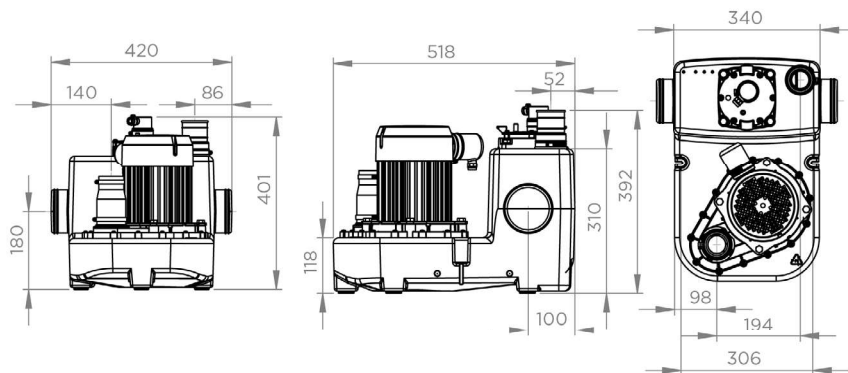

CURVE

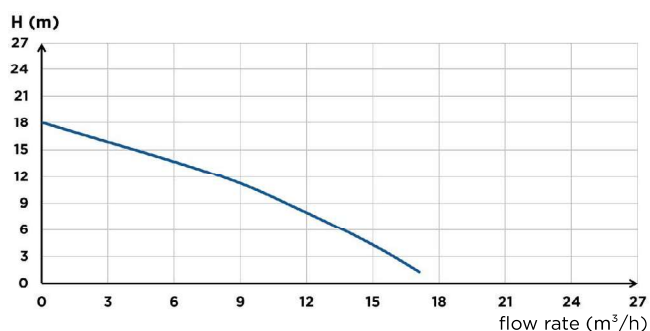

CONNECTIONS

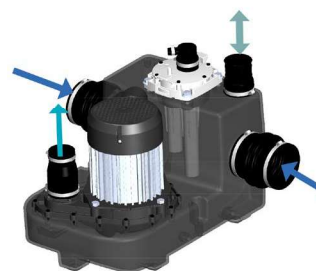

- External inlet diameter : 100 mm
- Discharge diameter ext. : 50 mm
- Ext. ventilation diameter : 50 mm

	Sanicubic 1 GR HP
Type of control box	Classic
Material	
Tank	HD PE
Pump housing	PA 12 GF
Motor housing	Aluminium
Impeller	PP GF
Electrical features	
Voltage (V)	220-240
Frequency (Hz)	50-60
Power consumption P1 (W)	2000
Power output P2 (W)	1400
Mode of operation	S3 30 %
IP rating	IPX4
Hydraulics	
Max. head (m)	18
Max. flow rate (m³/h)	17
External inlet diameter (mm)	100
Discharge diameter ext. (mm)	50
Ext. ventilation diameter (mm)	50
Total volume (L)	26
Useable volume (L)	12
ON level /OFF level (mm)	155/60
Alarm level (mm)	225
Max. temperature of the pumped liquid (5 min)	90°C
Type of impeller	Pro X K2 grinder
Type of activation	Pneumatic
Identification and logistics	
EAN code	3308815089614
Product code	30016